



## Barlow (and Barient) Winches

### Specifications, Parts Lists and Service Information

#### Notes

1. These specification sheets have been re-constructed from photocopies of original Barlow documents which are no longer available. The quality of the diagrams is the best that could be achieved from computer scanning of these photocopies.
2. Many Aloha yachts are equipped with "Barient" branded versions of the same winches. These carry different model numbers.
3. Barlow/Barient winches are no longer in business, having been taken over by Lewmar who don't seem to offer service support. According to their website The Australian Winch Co (see <http://www.arco-winch.com/barient.html>) has obtained much of the original Barlow/Barient tooling and has all of the technical data and product information for these winches. The website also contains more winch service information and advice on dismantling when the original Barlow/Barient dismantling tools are not available.

#### Contents

1. Models #15 & #16 1-speed Self Holding Winch
2. Models #19 & #23 2-speed Winch
3. Model #24 2-speed Winch
4. Model #25 2-speed Winch
5. Model #25 2-speed Adjustable Self Tailing Winch
6. Model #27 2-speed Winch
7. Model #27 2-speed Adjustable Self Tailing Winch

These details are provided by the Aloha Owners Association, and are compiled in good faith. However, they may not be correct and no responsibility will be accepted for any inaccuracies.

# BARLOW

## 1 SPEED SELF HOLDING WINCH

### #15 & #16

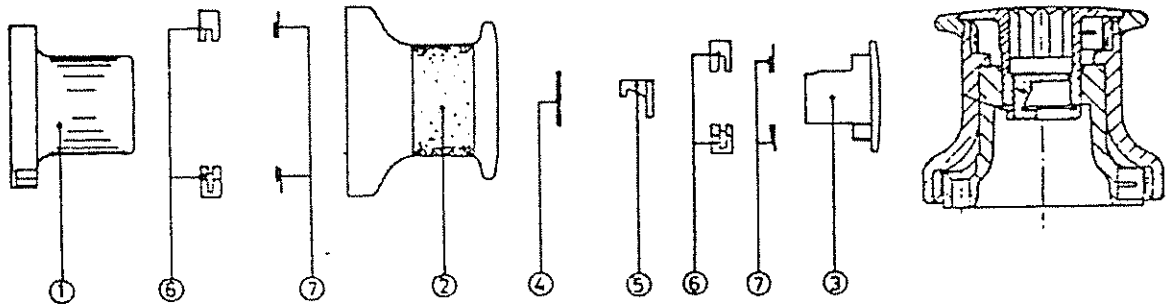

#### PLACEMENT OF PAWL SPRING

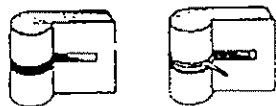

Place straight leg of spring against slit of pawl

Item No	Model #15 Part No	Model #16 Part No	Description	Qty
1	15-302	16-302	Base	1
2	15-304	16-304	Drum	1
3	15-305	16-305	Top cap	1
4	-- 01-328 --		Retaining Cup	1
5	-- 01-329 --		Retaining Plunger	1
6	-- 01-400 --		Pawl	4
7	-- 01-300 --		Spring	4

#### To dismantle:

(1) Depress retaining plunger until it locks inside and release top cap



(2) Remove top cap and drum



#### To assemble:



(1) Push retaining plunger back inside to original position



(2) Insert top cap into drum



(3) Place drum on base. Push down and rotate until retaining clip engages.

### SERVICE INFORMATION - #15 & #16

#### To install:

- Depress plunger (5), remove top cap (3) and drum (1) from base (1). Reset plunger (5) to its original position.
- Bolt base (1) to flat surface drilled to take four bolts 6mm dia. on a 66mm bolt circle dia. Use base (1) as a template. Use only a light coat of oil based sealing compound to seal the base.
- Check that plunger (5) does not protrude underside of top cap (3), insert top cap (3) into drum (2) and place on base (1). Push down and rotate until retaining clip (4) engages recess of base (1).

#### To lubricate:

- As step 1 of install above.
- Remove pawls (6) and springs (7) from top cap (3) and base (1). Do not remove retaining clip (4) or plunger (5) from top cap (3).
- Clean all parts in petroleum solvent, dry and grease with waterproof grease (Barlow Yacht Grease recommended). Lubricate the pawls (6) and springs (7) with a few drops of SAE30 oil. Note - Do not grease the pawls.
- Assemble as step 3 of install above.

#### Self Holding:

A feature of this winch is its unique tailing and self holding ability under load. The winch may be used by one person only. To operate, utilise the full height of the drum barrel using enough turns of the sheet until it jams against the underside of top flange. Do not allow the tail end to advance further than one turn.

#### Inspection and Lubrication:

Quarterly lubrication is recommended. Inspect more frequently during racing season.

# BARLOW

## 2 SPEED WINCH

### #19 & #23

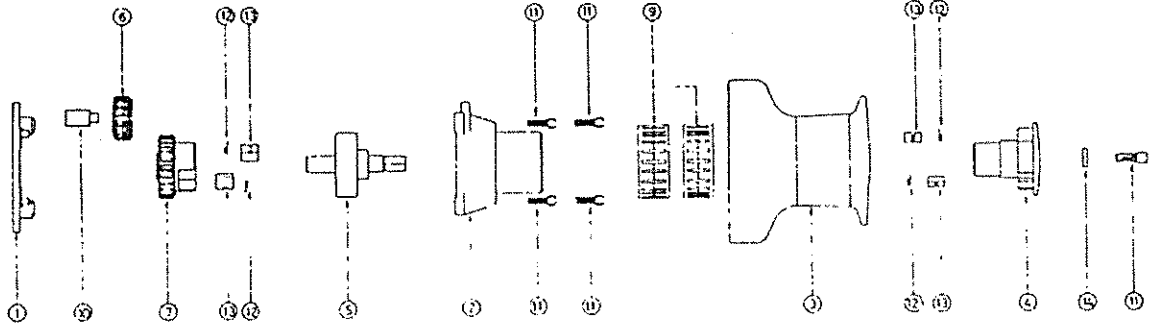

#### PLACEMENT OF PAWL SPRING

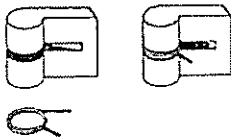

Place straight leg of spring against slit of pawl

Item No	Model #19 Part No	Model #23 Part No	Description	Qty
1	19-002	22-002	Base	1
2	19-003	23-003	Gearbox	1
3	-- 23-004 --		Drum	1
4	19-005	23-005	Top Cap	1
5	-- 23-006 --		Mainshaft Assembly	1
6	19-008	22-008	Idler Gear	1
7	19-012	22-012	Pinion	1
9	01-011		Bearing (Black)	2
10	19-013	01-124	Idler Shaft	1
11	01-205		Cap Screw	5
12	01-300		Torsion Spring	4
13	01-400		Ratchet Pawl	4
14	01-502		Retaining Washer	1

### SERVICE INFORMATION - #19 & #23

#### To install:

1. Using Barlow dismantling handle and 3/16 Allen key, remove the capscrew (11) in the top cap (4).
2. Lift drum (3) and top cap (4) together from gearbox (2) and base (1).
3. Bolt base (1) to flat surface drilled to take five bolts up to 6mm dia. on an 86mm bolt circle dia. It is not necessary to remove the gearbox (2) from the base (1). Use base (1) as a template.
4. Slide the drum (3) and top cap (4) together over the black bearings (9).
5. Firmly tighten the capscrew (11) in the top cap (4).

#### To lubricate:

1. Dismantle as in steps 1 & 2 of install above.
2. Remove the black bearings (9) from the gearbox (2). Remove four cap screws (16) and lift gearbox (2) from base (1). Remove mainshaft assembly (5) pinion (7) and its pawls (13) and springs (12) and remove idler gear (6) and shaft (10).
3. Remove top cap (4) from drum (3) and remove its pawls (13) and springs (12) and retaining washer (14).
4. Clean all parts in petroleum solvent, dry and grease with waterproof grease (Barlow Yacht Grease recommended). Lubricate the pawls (13) and springs (12) with a few drops of SAE30 oil. Note - Do not grease the pawls.
5. Reverse dismantling procedure.

#### Tools Required:

3/16 Allen Key, Barlow dismantling handle (01-821)

#### Inspection and Lubrication:

Quarterly lubrication is recommended. Inspect more frequently during racing season. Care should be taken in case of aluminium winch. To minimize wear, monthly cleaning and lubrication of the aluminium drum is advisable.

# BARLOW

## 2 SPEED WINCH

## #24

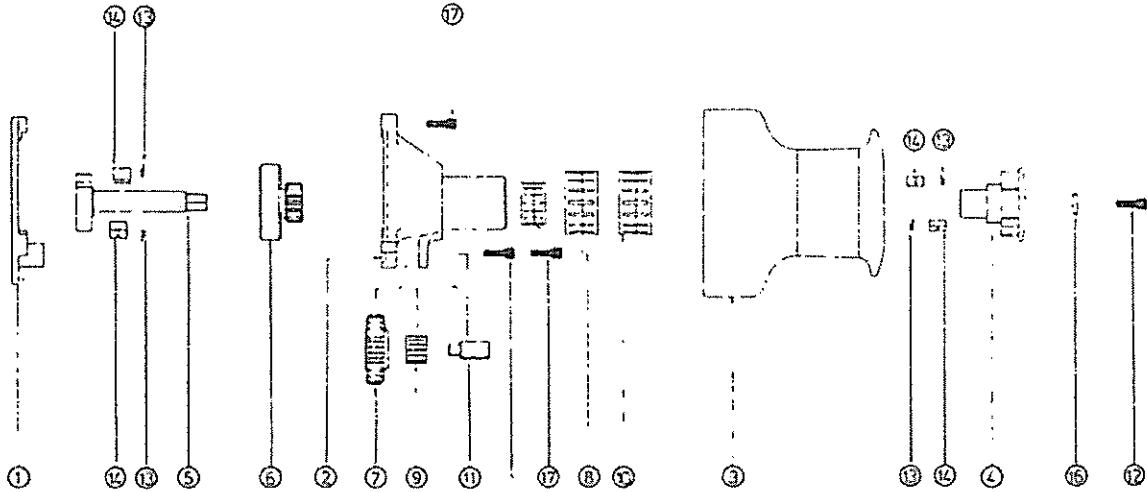

### PLACEMENT OF PAWL SPRING

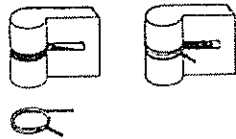

Place straight leg of spring against slit of pawl

Item No	Model #24 Part No	Description	Qty
1	24-002	Base	1
2	24-003	Gearbox	1
3	24-004	Drum	1
4	24-005	Top Cap	1
5	24-306	Mainshaft Assembly	1
6	25-007	Pinion	1
7	24-008	Idler Gear	1
8	01-012	Bearing (Gold)	1
9	01-013	Bearing (Green)	1
10	01-011	Bearing (Black)	2
11	01-155	Shaft	1
12	01-205	Cap Screw	1
13	01-300	Torsion Spring	4
14	01-400	Ratchet Pawl	4
16	01-502	Retaining Washer	1
16	01-231	Cap Screw	3

## SERVICE INFORMATION - #24

### To install:

1. Using Barlow dismantling handle and 3/16 Allen key, remove the capscrew (12) in the top cap (4).
2. Lift drum (3) and top cap (4) together from gearbox (2) and base (1).
3. Bolt base (1) to flat surface drilled to take six bolts up to 8mm dia. on an 111mm bolt circle dia. It is not necessary to remove the gearbox (2) from the base (1). Use base (1) as a template.
4. Slide the drum (3) and top cap (4) together over the black bearings (10).
5. Firmly tighten the capscrew (12) in the top cap (4)

### To lubricate:

1. Dismantle as in steps 1 & 2 of install above.
2. Remove the black bearings (10) from the gearbox (2). Remove three cap screws (17) and lift gearbox (2) from base (1).
3. Remove mainshaft assembly (5) with pinion (6), idler gear (7), green bearing (9) and shaft (11).
4. Remove pinion (6), pawls (14) and springs (13) from main shaft (5).
5. Remove top cap (4) from drum (3) and remove its pawls (14) and springs (13) and retaining washer (16).
6. Clean all parts in petroleum solvent, dry and grease with waterproof grease (Barlow Yacht Grease recommended). Lubricate the pawls (14) and springs (13) with a few drops of SAE30 oil. Note - Do not grease the pawls.
7. Reverse dismantling procedure.

### Tools Required:

1/4 & 3/16 Allen Keys, Barlow dismantling handle (01-821)

### Inspection and Lubrication:

Quarterly lubrication is recommended. Inspect more frequently during racing season. Care should be taken in case of aluminium winch. To minimize wear, monthly cleaning and lubrication of the aluminium drum is advisable.

# BARLOW

## 2 SPEED WINCH

### #25

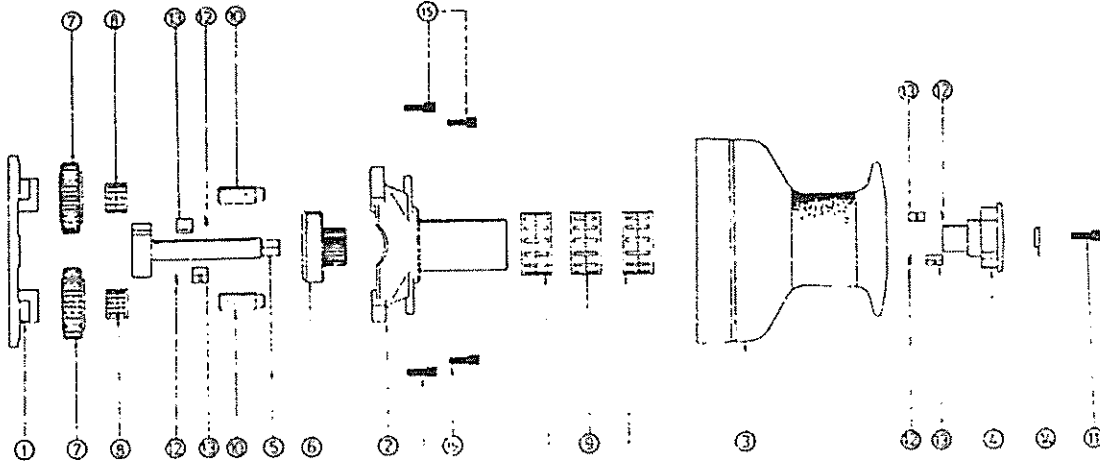

#### PLACEMENT OF PAWL SPRING

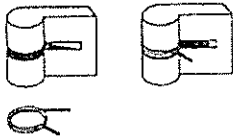

Place straight leg of spring against slit of pawl

Item No	Model #25 Part No	Description	Qty
1	25-202	Base	1
2	25-003	Gearbox	1
3	25-004	Drum	1
4	25-005	Top Cap	1
5	25-206	Mainshaft Assembly	1
6	25-007	Pinion	1
7	25-008	Idler Gear	2
8	01-013	Bearing (Green)	2
9	01-011	Bearing (Black)	3
10	01-154	Idler Shaft	2
11	01-205	Cap Screw	1
12	01-300	Torsion Spring	4
13	01-400	Ratchet Pawl	4
14	01-502	Retaining Washer	1
15	01-231	Cap Screw	4

## SERVICE INFORMATION - #25

### To install:

6. Using Barlow dismantling handle and 3/16 Allen key, remove the capscrew (11) in the top cap (4).
7. Lift drum (3) and top cap (4) together from gearbox (2) and base (1).
8. Bolt base (1) to flat surface drilled to take six bolts up to 8mm dia. on an 140mm bolt circle dia. It is not necessary to remove the gearbox (2) from the base (1). Use base (1) as a template.
9. Slide the drum (3) and top cap (4) together on the gearbox (2).
10. Firmly tighten the capscrew (11) in the top cap (4)

### To lubricate:

8. Dismantle as in steps 1 & 2 of install above.
9. Remove the top cap (4) from the drum (3) and remove pawls (13) and springs (12) and retaining washer (14) from top cap (4).
10. Remove the black bearings (9) from the gearbox (2). Remove the four cap screws (15) and lift gearbox (2) from base (1), leaving the shafts (10) in the base.
11. Remove the two idlers gears (7) and their green bearings (8).
12. Remove the mainshaft (5), pinion (6), from the base (1).
13. Remove the pinion (6) and the pawls (13) and springs (12) from main shaft (5).
14. Clean all parts in petroleum solvent, dry and grease with waterproof grease (Barlow Yacht Grease recommended). Lubricate the pawls (13) and springs (12) with a few drops of SAE30 oil. Note - Do not grease the pawls.
15. Reverse dismantling procedure.

### Tools Required:

1/4 & 3/16 Allen Keys, Barlow dismantling handle (01-821)

### Inspection and Lubrication:

Quarterly lubrication is recommended. Inspect more frequently during racing season. Care should be taken in case of aluminium winch. To minimize wear, monthly cleaning and lubrication of the aluminium drum is advisable.



## 2 SPEED SELF-TAILING WINCH

#25  
Self-Tail

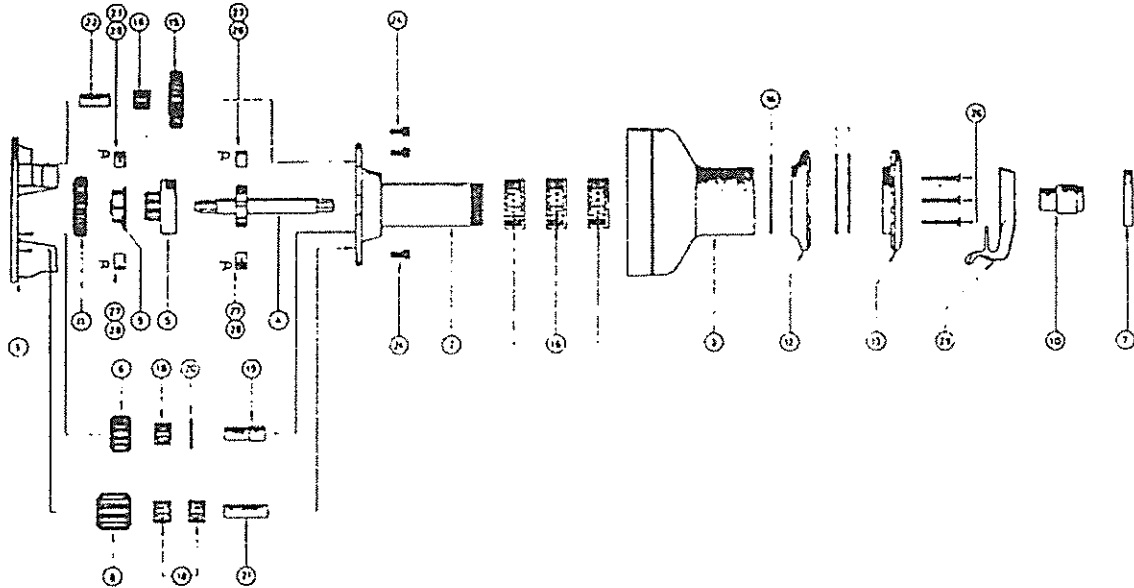

### PLACEMENT OF PAWL SPRING

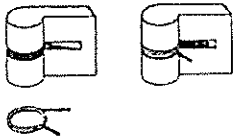

Place straight leg of spring  
against slit of pawl

Item No	Model #25ST Part No	Description	Qty
1	25-102	Base	1
2	25-103	Gearbox	1
3	25-104	Drum	1
4	25-306	Mainshaft Assembly	1
5	25-107	Pinion	1
6	25-108	Small Idler Gear	1
7	25-209	Retaining Nut	1
8	25-111	Drum Drive Pinion	1
9	25-115	High Speed Ratchet Drive	1
10	24-206	Mainshaft Top	1
11	25-117	High Speed Ratchet Gear	1
12	19-030	Bottom Jaw	1
13	19-031	Top Jaw	1
14	19-034	Spacer	3
15	25-008	Idler Gear	1
16	01-011	Bearing (Black)	3
18	01-013	Bearing (Green)	4
19	01-146	Idler Gear Shaft Stepped	1
20	01-147	Washer	1
21	01-148	Drum Drive Pinion Shaft	1
22	01-149	Idler Gear Shaft	1
24	01-231	Capscrew	3
26	01-237	Countersunk Screw	3
27	01-300	Torsion Spring	4
28	01-400	Ratchet Pawl	4
29	19-613	Rope Guide	1



## SERVICE INFORMATION - #25 Self Tailing

### To install:

1. Using Barlow sea spanner remove the retaining nut (7) in the rope guide (29).
2. With fingers between jaws and thumbs on the mainshaft top (10) lift drum (3) & rope guide (10) together from gearbox (2).
3. Bolt base (1) to flat surface drilled to take five bolts up to 8mm dia. on an 197.7mm bolt circle dia. It is not necessary to remove the gearbox (2) from the base (1). Use base (1) as a template.
4. With rope guide (29) in a suitable sheeting position replace drum (3) together over the gearbox (2).
5. Replace retaining nut (7) and tighten firmly.

### To lubricate:

1. Dismantle as in steps 1, 2 & 3 of install above.
2. Remove the black bearings (16) from gearbox (2).
3. Remove mainshaft top (10) and bearing (17) from top of gearbox (2).
4. Remove the three cap screws (24) and carefully lift gearbox (2) from base (1).
5. Lift out mainshaft (4) together with pinion (5), from high speed ratchet drive (9).
6. Remove the pinion (5) and the pawls (28) and springs (27) from main shaft (4).
7. Lift off idler gear (15) and green bearing (18) from idler gear shaft (22).
8. Remove drum drive pinion (8) and green bearings (18) from drum drive pinion shaft (21).
9. Remove small idler gear (6) together with its shaft (19) and washer (20) and separate them. Remove green bearing (18) from small idler gear (6).
10. Lift high speed ratchet gear (11) together with high speed ratchet drive (9) from base (1) and separate them. Remove pawls (28) and springs (27) from high speed ratchet drive (9).
11. Clean all parts in petroleum solvent, dry and grease with waterproof grease (Barlow Yacht Grease recommended). Lubricate the pawls (13) and springs (12) with a few drops of SAE30 oil. Note - Do not grease the pawls.
12. Reverse dismantling procedure.

### To adjust self-tailing jaw:

This winch can be re-set for larger or smaller sheets by changing the position of the spacers as follows:

1. Remove the retaining nut.
2. Lift off the drum and remove the rope guide.
3. Remove the screws holding the jaws.
4. For smaller sheets, remove a spacer between the jaws and place it under the bottom jaw with the other spacers. For larger sheets, remove the spacer under the bottom jaw and place it between the jaws with the other spacers.
5. Replace the screws and refit the rope guide, drum and retaining nut.

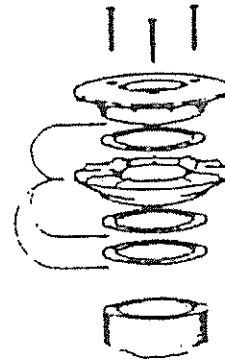

### Tools Required:

1/4 & 3/16 Allen Keys, Barlow sea spanner (01-615), small screwdriver

### Inspection and Lubrication:

Quarterly lubrication is recommended. Inspect more frequently during racing season. Care should be taken in case of aluminium winch. To minimize wear, monthly cleaning and lubrication of the aluminium drum is advisable.



## 2 SPEED WINCH

#27

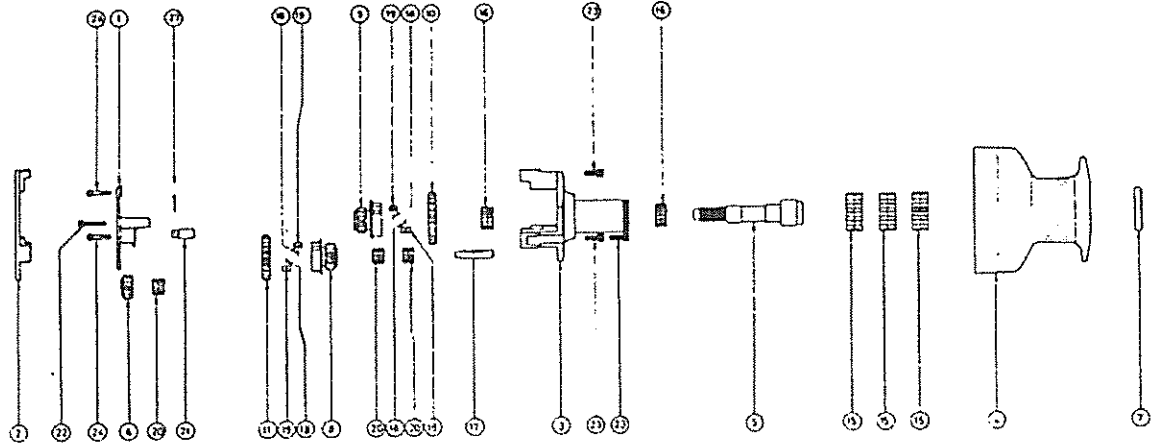

### PLACEMENT OF PAWL SPRING

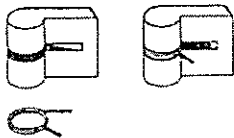

Place straight leg of spring against slit of pawl

Item No	Model #27 Part No	Description	Qty
1	27-001	Gearbox Plate	1
2	27-002	Base	1
3	27-003	Gearbox	1
4	27-004	Drum Assembly	1
5	27-006	Mainshaft	1
6	27-008	Idler Gear	1
7	27-009	Retaining Nut	1
8	27-011	Drum Drive Pinion	1
9	27-012	Centre Pinion	1
10	27-013	Centre Ratchet Gear	1
11	27-015	Drum Drive Ratchet	1
15	01-011	Bearing (Black)	3
16	01-012	Bearing (Gold)	2
17	01-144	Drum Drive Pinion Shaft	1
18	01-300	Torsion Spring	4
19	01-400	Ratchet Pawl	4
20	01-013	Bearing (Green)	3
21	01-145	Idler Gear Shaft	1
22	01-206	Capscrew	1
23	01-231	Capscrew	3
24	01-227	Special Capscrew	2
27	01-232	Split Pin	1

## SERVICE INFORMATION - #27

### To install:

1. Using Barlow sea spanner remove retaining nut (7) from top of drum (4) and remove drum.
2. Remove 3 capscrews (23) in gearbox (3).
3. Keeping gearbox assembly complete, remove from base (2).
4. Bolt base (2) to flat surface drilled to take five bolts up to 9.5mm dia. on an 143mm bolt circle dia. Use base (2) as a template.
5. To assemble winch, reverse dismantling procedure.

### To lubricate:

1. Dismantle as in step 1 above, then remove black bearings (15) from gearbox.
2. As in steps 1 & 3 above, then invert gearbox assembly making sure the mainshaft (5) does not fall out.
3. Remove two special capscrews (24) and long capscrew (22) from gearbox plate (1) and remove gearbox plate assembly from gearbox (3).
4. Remove split pin (27) from idler gear shaft (21) and remove idler gear shaft (21).
5. Remove idler gear (6) from gearbox plate (1) and remove its bearing (20).
6. Remove drum drive pinion (8) and its ratchet gear (11) and separate them. (On some Barlow 27 winches the drum drive pinion shaft (17) may also be removed). Remove pawls (19) and springs (18) and two bearings (20) from the drum drive pinion (8).
7. Remove centre pinion (9) and its ratchet gear (10) and separate them. Remove pawls (19) and springs (18) from the centre pinion (9).
8. Lift mainshaft (5) from the gearbox (3).
9. Remove bearings (16) from inside end of gearbox (3).
10. Clean all parts in petroleum solvent, dry and grease with waterproof grease (Barlow Yacht Grease recommended). Lubricate the pawls (19) and springs (18) with a few drops of SAE30 oil. Note - Do not grease the pawls.
11. Assemble winch in reverse order to that shown above.

Note – for winches manufactured before 1980 take care when refitting the ratchet gear (11) to its drum drive pinion (8) to ensure that the two surfaces stamped 'R' are on the same side. Failure to do so will cause the pawls and winch to slip.

### Tools Required:

1/4 & 3/16 Allen Keys, Barlow sea spanner (01-615)

### Inspection and Lubrication:

Quarterly lubrication is recommended. Inspect more frequently during racing season. Care should be taken in case of aluminium winch. To minimize wear, monthly cleaning and lubrication of the aluminium drum is advisable.



## 2 SPEED SELF-TAILING WINCH

#27  
Self Tail

### ADJUSTABLE SELF TAILER

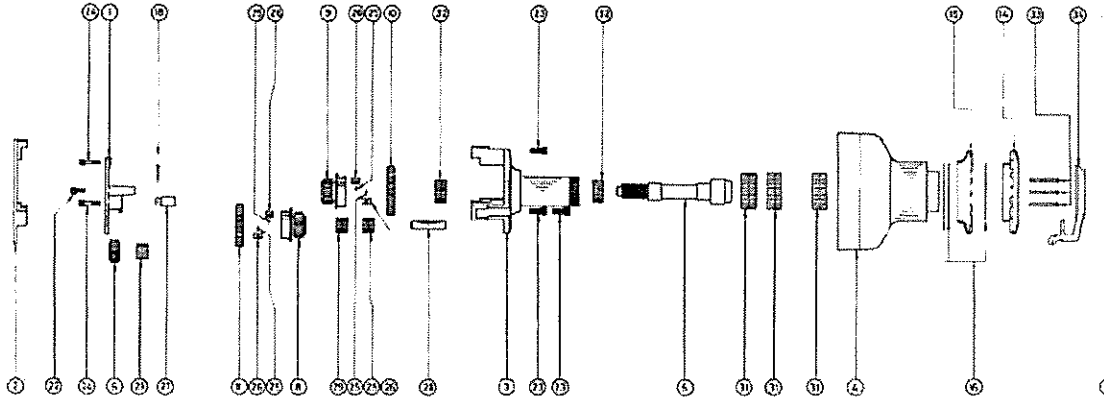

#### PLACEMENT OF PAWL SPRING



Place straight leg of spring  
against slit of pawl

Item No	Model #27 Part No	Description	Qty
1	27-001	Gearbox Plate	1
2	27-002	Base	1
3	27-003	Gearbox	1
4	27-004	Drum Assembly	1
5	27-006	Mainshaft	1
6	27-008	Idler Gear	1
7	27-009	Retaining Nut	1
8	27-011	Drum Drive Pinion	1
9	27-012	Centre Pinion	1
10	27-013	Centre Ratchet Gear	1
11	27-015	Drum Drive Ratchet	1
14	27-231	Top Jaw	1
15	27-230	Bottom Jaw	1
16	27-034	Spacer	3
18	01-232	Split Pin	1
22	01-206	Capscrew	1
23	01-231	Capscrew	3
24	01-227	Special Capscrew	2
25	01-300	Torsion Spring	4
26	01-400	Ratchet Pawl	4
27	01-145	Idler Gear Shaft	1
28	01-144	Drum Drive Pinion Shaft	1
29	01-013	Bearing (Green)	3
31	01-011	Bearing (Black)	3
32	01-012	Bearing (Gold)	2
33	01-237	C-Sunk Screw	3
34	27-613	Rope Guide	1

## SERVICE INFORMATION - #27 Self Tail

### To install:

1. Using Barlow sea spanner remove retaining nut (7) in the rope guide (34).
2. With fingers between jaws and thumbs on the mainshaft (5) lift drum (4) and rope guide (12) together from the gearbox (3).
3. Remove 3 capscrews (23) in gearbox (3).
4. Keeping gearbox assembly complete, remove from base (2).
5. Bolt base (2) to flat surface drilled to take five bolts up to 9.5mm dia. on a 143mm bolt circle dia. Use base (2) as a template.
6. Replace gearbox assembly on the base (2).
7. Replace the three capscrews (23) in gearbox (3).
8. With rope guide (34) in a suitable sheeting position replace drum (4) together over the gearbox (3).
9. Replace retaining nut (7) and tighten firmly.

### To lubricate:

1. Dismantle as in step 1 & 2 above.
2. Invert gearbox assembly making sure the mainshaft (5) does not fall out.
3. Remove two special capscrews (24) and long capscrew (22) from gearbox plate (1) and remove gearbox plate assembly from gearbox (3).
4. Remove split pin (27) from idler gear shaft (21) and remove idler gear shaft (21).
5. Remove idler gear (6) from gearbox plate (1) and remove its bearing (20).
6. Remove drum drive pinion (8) and its ratchet gear (11) and separate them. (On some Barlow 27 winches the drum drive pinion shaft (17) may also be removed). Remove pawls (19) and springs (18) and two bearings (20) from the drum drive pinion (8).
7. Remove centre pinion (9) and its ratchet gear (10) and separate them. Remove pawls (19) and springs (18) from the centre pinion (9).
8. Lift mainshaft (5) from the gearbox (3).
9. Remove bearings (16) from inside end of gearbox (3).
10. Clean all parts in petroleum solvent, dry and grease with waterproof grease (Barlow Yacht Grease recommended). Lubricate the pawls (19) and springs (18) with a few drops of SAE30 oil. Note - Do not grease the pawls.
11. Assemble winch in reverse order to that shown above.

Note – for winches manufactured before 1980 take care when refitting the ratchet gear (11) to its drum drive pinion (8) to ensure that the two surfaces stamped 'R' are on the same side. Failure to do so will cause the pawls and winch to slip.

### To adjust self-tailing jaw:

This winch can be re-set for larger or smaller sheets by changing the position of the spacers as follows:

1. Remove the retaining nut.
2. Lift off the drum and remove the rope guide.
3. Remove the screws holding the jaws.
4. For smaller sheets, remove a spacer between the jaws and place it under the bottom jaw with the other spacers. For larger sheets, remove the spacer under the bottom jaw and place it between the jaws with the other spacers.
5. Replace the screws and refit the rope guide, drum and retaining nut.

### Tools Required:

1/4 & 3/16 Allen Keys, Barlow sea spanner (01-615), small screwdriver.

### Inspection and Lubrication:

Quarterly lubrication is recommended. Inspect more frequently during racing season. Care should be taken in case of aluminium winch. To minimize wear, monthly cleaning and lubrication of the aluminium drum is advisable.

